

UNION PACIFIC HISTORICAL SOCIETY

UNION PACIFIC CLASS S-40-6 DOUBLE DECK STOCK CAR ASSEMBLY INSTRUCTIONS

PLEASE READ BEFORE GETTING STARTED!!

This is a highly detailed craftsman style kit. With careful planning and test fitting of parts prior to assembly, your end results will be a beautiful model that is a joy to build and can be proudly displayed by the hands of its builder. In order to bring you the most accurate representation of a UP S-40-6 stock car, it was necessary to manufacture this kit using parts and components from several different model manufacturers. With this being the case, you'll note that some sanding or filing will be required to make a perfect fit when assembling some parts. With any craftsman style kit some painting and touch up will be required. The paint for a correct color match for this kit is available through P-B-L, P.O. Box 659, Ukiah, CA 95482, PH 707 462 7680. Please ask for Star Brand UP/SP Boxcar red.

GETTING STARTED: The Body assembly.

- 1) Using a large mill file remove any tabs or protrusions from the sides and edges of the floor until smooth and even paying attention not to nick the extended floor boards for the door opening.
- 2) Using a pair of de-spruing nippers or a sharp blade, remove sides and ends from their respective sprues. When finished, clean up all edges with your file making all edges nice and sharp. Using the diagram, position and glue the letter boards and numbers in their respective positions.
- 3) Test fit the sides to the ends. In order to make the corner irons' metal work appear to wrap around the car, it was necessary to extend the end corner iron past the end. Please make sure it fits into the side notch perfectly. When satisfied with your alignment, go ahead and assemble your joint using a small brush and liquid type glue. Repeat this for the second set of sides and ends.
- 4) Now assemble your two body halves together in the same manner as the previous step paying attention that assembly is true and square.
- 5) Next we will install the floor. PLEASE PAY CAREFUL ATTENTION to the orientation of the "A" and "B" ends. They are clearly marked inside the coupler pocket. The "B" on the car body is the end with the brakewheel mounting pad. Test fit your floor to make sure it slides nicely into door opening etc. If it does not, use an emery board and sand a little of the door opening away to get a perfect fit. Once happy with your fit up, glue the floor in place along all the joints or seams.
Note: If you're going to weight your car, now is the time to add your favorite material. A load of sheep would be perfect!!
- 6) Now's the time to clean out the grab iron holes. Using a #78 drill in a pin vise ream out all of the holes for the grab irons.
- 7) Using the pre-bent grab irons only install the lower portion of grabs that are located below the double deck. Use a drop of superglue on the backside to secure into place. Please note that there are two sizes of L shaped "safety grabs" that are located on the lower row of the sides and ends. Please pay attention to these locations.
- 8) Next you will add the double deck to the inside of your body assembly. You will have to file a little off of each end to make a perfect fit inside the car body. Using the exploded diagrams, please note that the double deck sits on the two tabs located on the backside of the ends. Glue in place along side seams.
- 9) Install the remainder of your grab irons using the same method of glue as you did for the lower portion.
- 10) Installing the roof will complete the body assembly. When fitting up please note the roof ends are to be flush with the outer edges of the ends so make sure you have it positioned correctly before final gluing. Suggestion: Tack glue the roof in the 4 corners and align to your liking and then do final gluing.

Details, details!

- 11) After cleaning up the door edges, go ahead and stick the door on using the diagrams supplied. Please note that stock cars had no lower door guides so it is appropriate for the bottom of the door to flop out a little.
- 12) Using locating pins as a guide, install the running board (roof walk) to the roof.
- 13) The end brake gear is next. Using diagrams once again, glue the Ajax brake housing and brake wheel into place followed by the brake chain and rod.
- 14) Next glue up the brake platform assembly. Please use diagram for correct orientation of the parts as there are left and right side supports. When completely dry, apply to the end using locating slots under the brake wheel.

15) Insert the strirrup steps into holes provided.

16) Using the pre-bent running board (roof walk) support, glue into place under running board and let the legs fall where they may. Please note the support may have to be re-shaped a bit due to handling and packaging abuse.

17) Now we can add the roof corner grab irons. Using locating holes in roof apply.

The part you don't see, The Underbody.

18) After cleaning up the center sill, locate it on the center of your floor and glue in place.

19) Using the photo provided locate all of the brake gear hardware and glue in their respective holes and or brackets.

20) Using your favorite brand and style of coupler install using manufacture instructions and glue or screw (screws not included) the draftgear cover onto the coupler box.

21) Using screws provided screw you trucks onto the body bolsters making sure that they are free to float around and not to snug for trouble free operation.

Conclusion,

Now that you can see your assembled car in 3D you'll note areas that need touch up. We suggest using an airbrush and fogging on the touch up paint in the areas needed. If you want you car to look like to prototype add a small amount of weathering to give her that scale appearance and now you're ready to create envy with all your pals at the local train club.

Thank you for purchasing this kit from the UPHS. It's supporters such as yourselves that make "one of a kind" and unique projects like this possible. We know you appreciate the efforts that goes into a project like this and we look forward to your continued support with our future endeavors.

UPHS 2009 Board of Directors.

UPHS 2009 Model Project Committee.

UNION PACIFIC CLASS S-40-6 DOUBLE DECK STOCK CAR

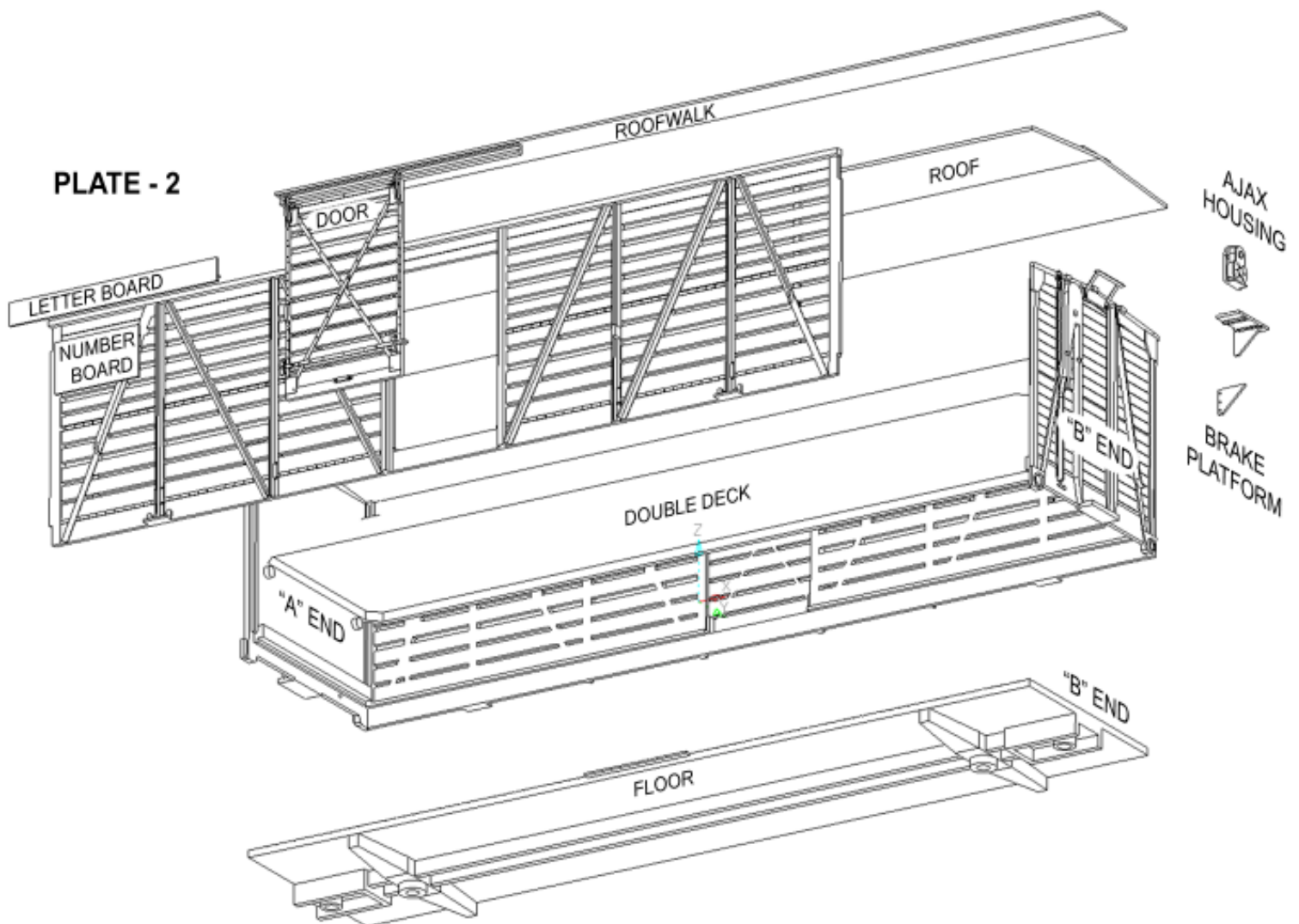
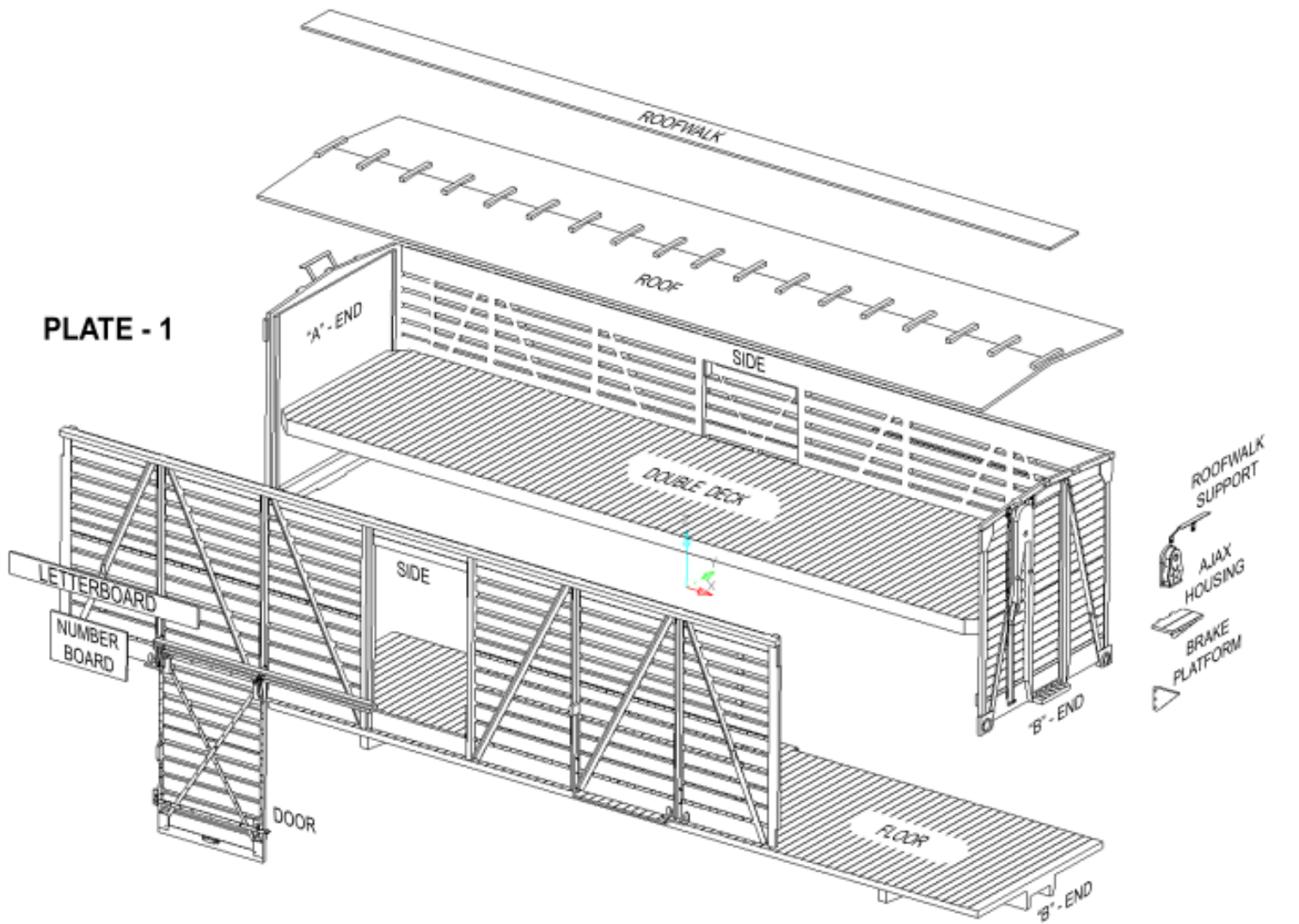

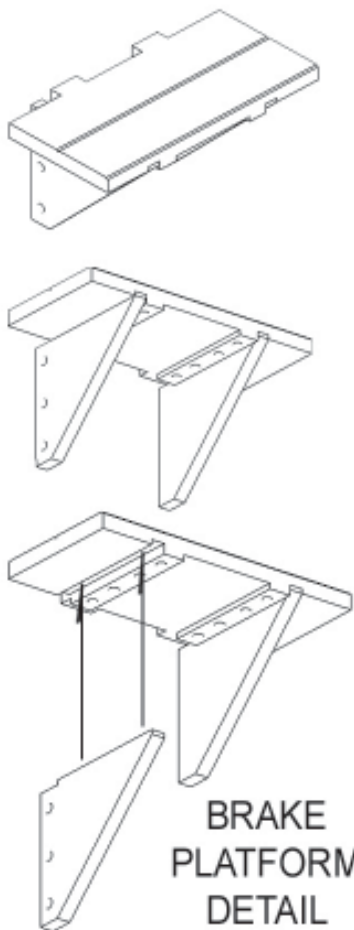

DETAIL SHOWING LETTERBOARD AND NUMBER BOARD INSTALATION

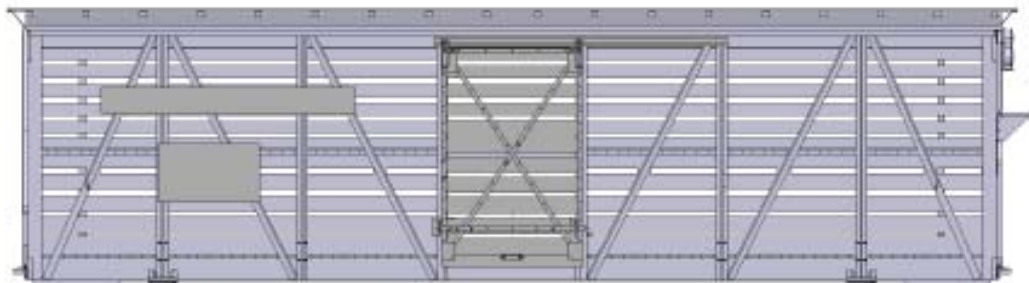
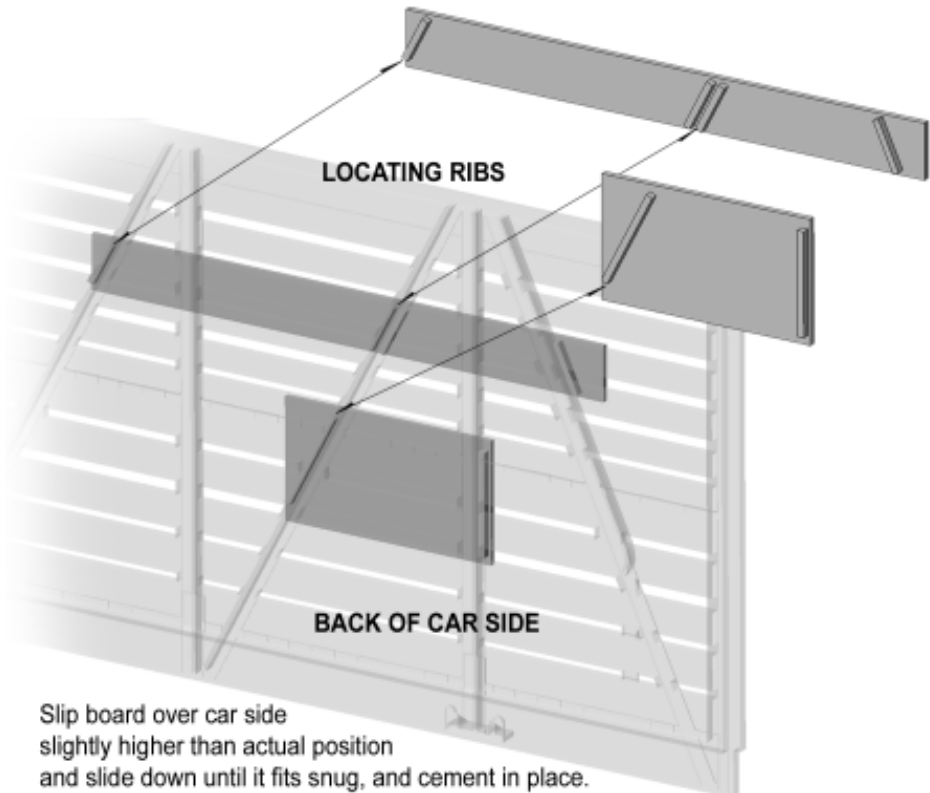

SIDE VIEW FOR LOCATING LETTER AND NUMBER BOARDS



Underbody details